

# COLDWORKS IRONWORKERS

V-55

V-45

MODEL	V-100	V-55	V-45
Throat depth	12" (304 mm)	8" (203 mm)	5" (127 mm)
Open height	15 1/2" (393 mm)	13 1/2" (343 mm)	12 1/4" (311 mm)
Closed height	10 1/4" (260 mm)	9 1/4" (235 mm)	8 1/4" (210 mm)
Stroke	5 1/4" (133 mm)	4 1/4" (108 mm)	4" (101 mm)
Table Size	14 1/2" x 21" (368 x 533 mm)	10" x 17" (254 x 432 mm)	8" x 16 1/2" (203 x 419 mm)
Punch (short ton)	100 tons	55 tons	45 tons
Hole size (max. material)	1 1/8", 28 mm (1", 25 mm)	13/16", 20 mm (3/4", 19 mm)	1", 25 mm (1/2", 12 mm)
Max. Hole (special tooling)	5", 127 mm (3/16", 4 mm)	5", 127 mm (1/8" x 3 mm)	1 1/2", 38 mm (3/16", 4 mm)
Plate shear with Fixed hold down	20 1/2" (520 mm) Long 1" x 12" (25 mm x 304 mm) 3/4" x 18" (19 mm x 457 mm) 1/2" x 20" (12 mm x 508 mm)	15 1/2" (393 mm) Long 1" x 4" (25 mm x 101 mm) 3/4" x 10" (19 mm x 254 mm) 5/8" x 15" (15 mm x 381 mm)	13" (330 mm) Long 5/8" x 6" (15 mm x 152 mm) 1/2" x 8" (12 mm x 203 mm) 1/4" x 13" (6 mm x 330 mm)
Angle shear (with fixed hold down V-55 only)	6" x 6" x 5/8" (152 x 152 x 15 mm)	5" x 5" x 3/8" (127 x 127 x 9.5 mm) Fixed Hold Down - 4" x 4" x 1/2" (101 x 101 x 12 mm)	3 1/2" x 3 1/2" x 5/16" (88 x 88 x 8 mm)
Bar Shear (Round)	1 1/4" (31 mm)	1" (25 mm)	1/2" (12 mm)
Coper-Notcher(Max.)	4" x 6" x 3/8" (101 x 152 x 9.5 mm)	2 3/4" x 4" x 1/4" (69 x 101 x 6 mm)	2 1/4" x 3" x 1/4" (57 x 76 x 6 mm)
Bending Attach	12" (304 mm)	8" (203 mm)	6" (152 mm)
Punch end Stroke per Minute	40 @ 3/4" (19 mm)	60 @ 1/2" (12mm)	50 @ 1/2" (12mm)
Work Station Height	43" (1092 mm)	43" (1092 mm)	43" (1092 mm)
Tank Capacity	25 Gallons	20 Gallons	12 Gallons
Motor	15 HP	10 HP	6.5 HP
Dimensions	35" x 90" x 66 1/2"	24" x 66" x 60"	24" x 55" x 58"
Weight (Net)	5650 lbs	2600 lbs	1100 lbs

All Specifications & design are subject to change without prior notice

## IRONWORKERS

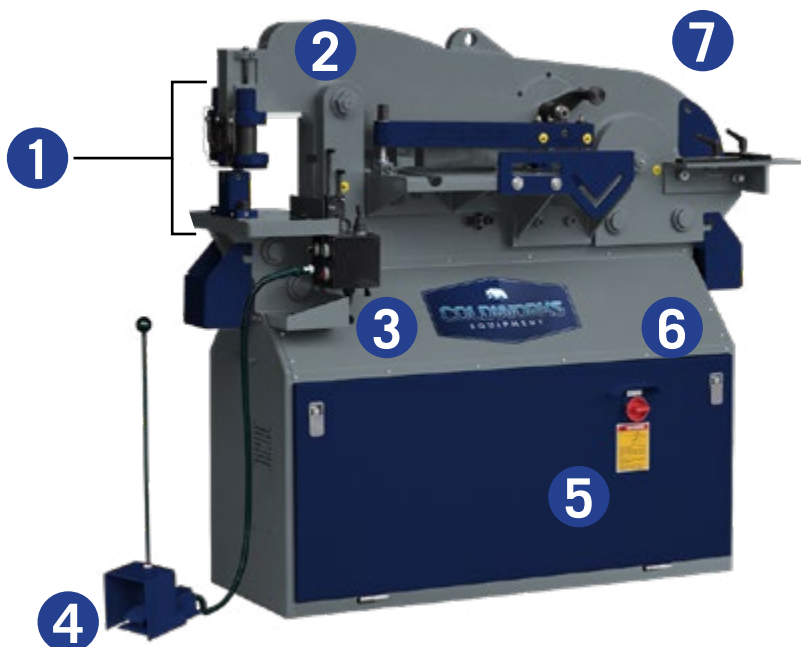

1

**Quick-Release Punching-Die**

- Simple: effortless to fasten or loosen
- Fast: Rapid tool change
- Diverse: Interchangeable design ensures vast capability & adaptation

2

**Limit-Switch-Adjustment**

- Range flexible: With wider range of stroke, increased power is available

3

**Joy-Stick-Control (JOG Mode Only)**

- Accessible design: Joy sticks from both the front and the rear offer flexible operation
- 5 positioning control: Intuitive adjust through speeds - fast/neutral/low & up/low

5

**Heavy Duty Powerful System**

- Strong force: Hydraulic system can perform jobs smoothly & consistently
- Machine Protection: Hydraulic system able to prevent damage from excessive workload and unsuitable work piece input

4

**Foot-Switch-Control**

- Extends the control: Using foot pedal allows hands free operation
- Control Accessible: Connect-ports from both ends of the machine makes operation convenient

6

**Auto Power Off Switch**

- Safety Protection to users: Power shut-down when cabinet door is open

7

**Clamping-Thickness-Adjustment**

- Arc-like switch: Intuitive control with three stages settings
- To be fast or flexible: Use setting or make fine-tune adjustments

## IRONWORKER STANDARD FEATURES

- 1 Punch attachment
- 2 Manual Back Gauge & Side Guard
- 3 Fixed angle hold down (for V-55 only)
- 4 Bending Attachment
- 5 Attached oil tank
- 6 Coping or notching

*Depend on Us  
Because COLDWORKS*

ORDER NOW 903.663.8500

  
**COLDWORKS**  
EQUIPMENT

IRONWORKERS OPTIONAL EQUIPMENT

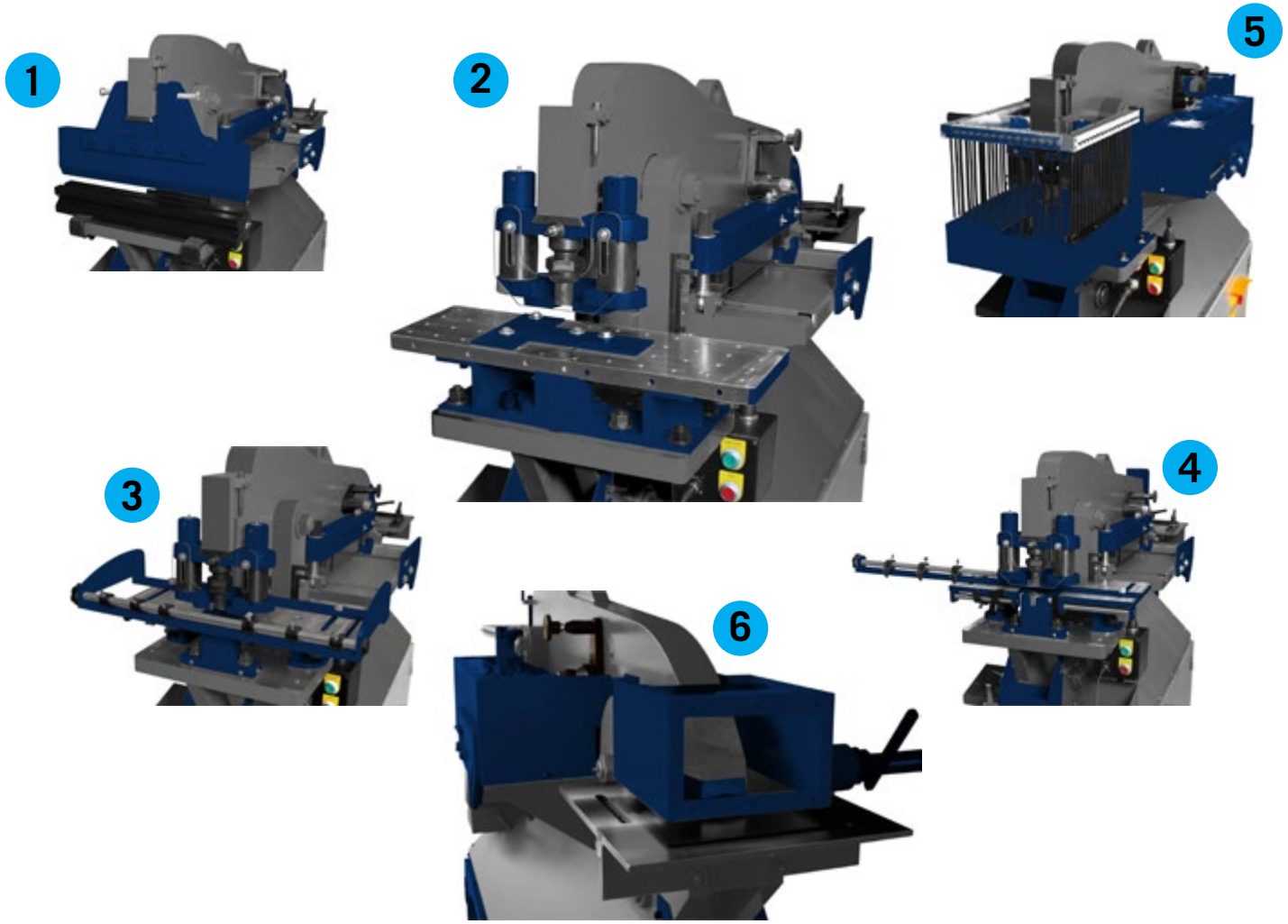

Optional Equipment / Features

- 1 24" bending attachment
- 2 Plate Gauging table
- 3 Quick set table assembly with quick set bar gauge assembly
- 4 Safety rear guard
- 5 Quick set angle gauge assembly
- 6 Safety front guard + chip bucket

Coldworksequipment.com

ORDER NOW 903.663.8500

